



L4TDM-PSA

7-16 DIN Male Positive Stop™ for 1/2 in AL4RPV-50, LDF4-50A, HL4RPV-50 cable

Product Classification

Brand	HELIAX® Positive Stop™
Product Type	Wireless and radiating connector

General Specifications

Interface	7-16 DIN Male
Body Style	Straight
Brand	HELIAX® Positive Stop™
Harmonized System (HS) Code	854420 (Coaxial cable and other coaxial electric conductors)
Mounting Angle	Straight
Ordering Note	CommScope® standard product (Global)

Electrical Specifications

Connector Impedance	50 ohm
Operating Frequency Band	0 – 8800 MHz
Cable Impedance	50 ohm
3rd Order IMD, typical	-120 dBm @ 910 MHz
3rd Order IMD Test Method	Two +43 dBm carriers
RF Operating Voltage, maximum (vrms)	1415.00 V
dc Test Voltage	4000 V
Outer Contact Resistance, maximum	1.50 mOhm
Inner Contact Resistance, maximum	0.80 mOhm
Insulation Resistance, minimum	5000 MOhm
Average Power	1.1 kW @ 900 MHz
Peak Power, maximum	40.00 kW
Insertion Loss, typical	0.05 dB
Shielding Effectiveness	-110 dB

L4TDM-PSA

Outline Drawing

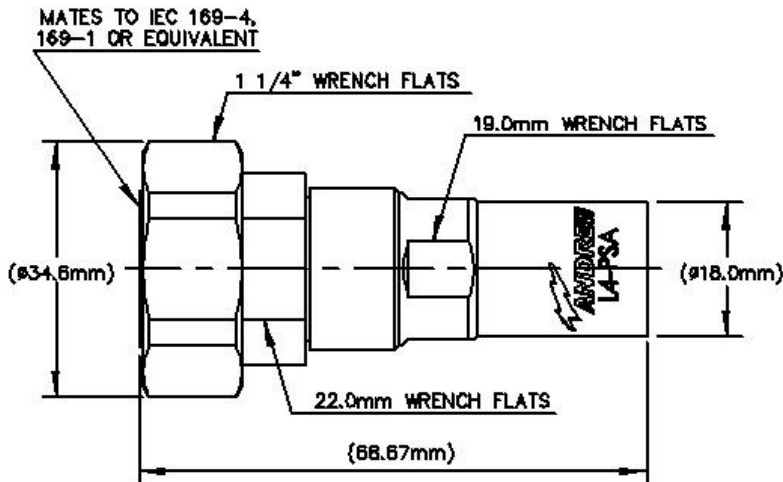

Mechanical Specifications

Outer Contact Attachment Method	Ring-flare
Inner Contact Attachment Method	Captivated
Outer Contact Plating	Trimetal
Inner Contact Plating	Silver
Attachment Durability	25 cycles
Interface Durability	500 cycles
Interface Durability Method	IEC 61169-4:9.5
Connector Retention Tensile Force	890 N 200 lbf
Connector Retention Torque	5.42 N-m 48.00 in lb
Insertion Force	200.17 N 45.00 lbf
Insertion Force Method	IEC 61169-1:15.2.4
Coupling Nut Proof Torque	25.00 N-m 221.27 in lb
Coupling Nut Retention Force	1000.00 N 224.81 lbf
Coupling Nut Retention Force Method	MIL-C-39012C-3.25, 4.6.22

Dimensions

Nominal Size	1/2 in
Diameter	34.60 mm 1.36 in
Length	68.67 mm 2.70 in
Weight	120.09 g 0.26 lb

Environmental Specifications

Operating Temperature	-55 °C to +85 °C (-67 °F to +185 °F)
Storage Temperature	-55 °C to +85 °C (-67 °F to +185 °F)
Immersion Depth	1 m

L4TDM-PSA

Immersion Test Mating	Unmated
Immersion Test Method	IEC 60529:2001, IP68
Water Jetting Test Mating	Unmated
Water Jetting Test Method	IEC 60529:2001, IP66
Moisture Resistance Test Method	MIL-STD-202F, Method 106F
Mechanical Shock Test Method	MIL-STD-202, Method 213, Test Condition I
Thermal Shock Test Method	MIL-STD-202F, Method 107G, Test Condition A-1, Low Temperature -55 °C
Vibration Test Method	IEC 60068-2-6
Corrosion Test Method	MIL-STD-1344A, Method 1001.1, Test Condition A

Return Loss/VSWR

Frequency Band	VSWR	Return Loss (dB)
45–1000 MHz	1.02	39.00
1010–2200 MHz	1.03	37.00
2200–3000 MHz	1.05	33.00
3010–4000 MHz	1.07	29.00
4010–6000 MHz	1.11	26.00
6010–8000 MHz	1.15	23.00

Regulatory Compliance/Certifications

Agency	Classification
RoHS 2011/65/EU	Compliant by Exemption
China RoHS SJ/T 11364-2006	Above Maximum Concentration Value (MCV)
ISO 9001:2008	Designed, manufactured and/or distributed under this quality management system



* Footnotes

Immersion Depth	Immersion at specified depth for 24 hours
Insertion Loss, typical	$0.05\sqrt{\text{freq (GHz)}}$ (not applicable for elliptical waveguide)